

MEDIUM POWER AMPLIFIER

ADVANCE DATA

- SILICON EPITAXIAL PLANAR NPN TRANSISTORS
- MINIATURE PLASTIC PACKAGE FOR APPLICATION IN SURFACE MOUNTING CIRCUITS
- GENERAL PURPOSE MAINLY INTENDED FOR USE IN MEDIUM POWER INDUSTRIAL APPLICATION AND FOR AUDIO AMPLIFIER OUTPUT STAGE
- PNP COMPLEMENTS ARE STZT2222 AND STZT2222A RESPECTIVELY

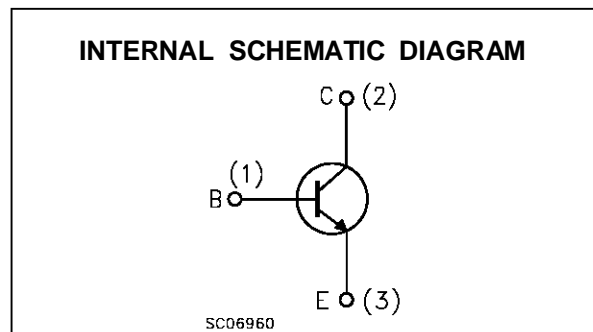
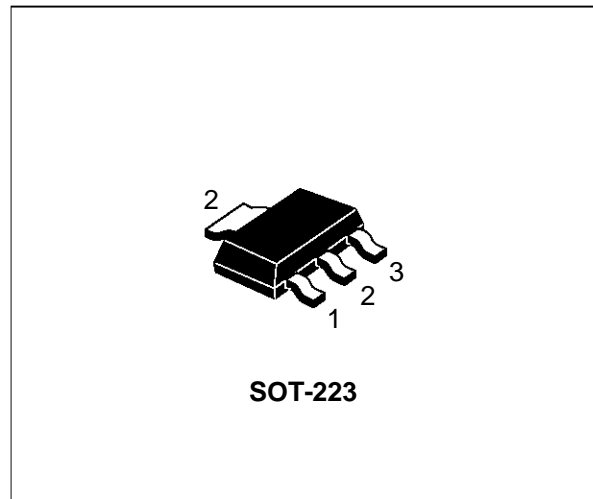

ABSOLUTE MAXIMUM RATINGS

Symbol	Parameter	Value		Unit
		STZT2907	STZT2907A	
V_{CBO}	Collector-Base Voltage ($I_E = 0$)	-60	-60	V
V_{CEO}	Collector-Emitter Voltage ($I_B = 0$)	-40	-60	V
V_{EBO}	Emitter-Base Voltage ($I_C = 0$)	-5		V
I_C	Collector Current	-0.8		A
P_{tot}	Total Dissipation at $T_c = 25^\circ\text{C}$	-1.5		W
T_{stg}	Storage Temperature	-65 to 150		$^\circ\text{C}$
T_j	Max. Operating Junction Temperature	150		$^\circ\text{C}$

STZT2907/STZT2907A

THERMAL DATA

$R_{thj-amb}$	Thermal Resistance Junction-Ambient	Max	83.3	$^{\circ}\text{C}/\text{W}$
$R_{thj-tab}$	Thermal Resistance Junction-Collector Tab	Max	10	$^{\circ}\text{C}/\text{W}$

• Mounted on a ceramic substrate area = 30 x 35 x 0.7 mm

ELECTRICAL CHARACTERISTICS ($T_{case} = 25^{\circ}\text{C}$ unless otherwise specified)

Symbol	Parameter	Test Conditions	Min.	Typ.	Max.	Unit
I_{CBO}	Collector Cut-off Current ($I_E = 0$)	$V_{CB} = \text{rated } V_{CBO}$ $V_{CB} = \text{rated } V_{CBO} \quad T_{amb} = 125^{\circ}\text{C}$			-20 -10	nA μA
I_{CEX}	Collector Cut-off Current ($V_{BE} = 0.5\text{V}$)	$V_{CE} = -30\text{ V}$ for STZT2222A			-50	nA
I_{BEX}	Base Cut-off Current ($V_{BE} = 0.5\text{V}$)	$V_{CE} = -30\text{ V}$ for STZT2222A			-50	nA
$V_{(BR)CBO}$	Collector-Base Breakdown Voltage ($I_E = 0$)	$I_C = -10\ \mu\text{A}$	-60			V
$V_{(BR)CEO}^*$	Collector-Emitter Breakdown Voltage ($I_B = 0$)	$I_C = -10\text{ mA}$ for STZT2907 for STZT2907A	-40 -60			V V
$V_{(BR)EBO}$	Emitter-Base Breakdown Voltage ($I_C = 0$)	$I_E = -10\ \mu\text{A}$	-5			V
$V_{CE(sat)}^*$	Collector-Emitter Saturation Voltage	$I_C = -150\text{ mA}$ $I_B = -15\text{ mA}$ $I_C = -500\text{ mA}$ $I_B = -50\text{ mA}$			-0.4 -1.6	V V
$V_{BE(sat)}^*$	Base-Emitter Saturation Voltage	$I_C = -150\text{ mA}$ $I_B = -15\text{ mA}$ $I_C = -500\text{ mA}$ $I_B = -50\text{ mA}$			-1.3 -2.6	V V
h_{FE}^*	DC Current Gain	$I_C = -0.1\text{ mA}$ $V_{CE} = -10\text{ V}$ for STZT2907 for STZT2907A $I_C = -1\text{ mA}$ $V_{CE} = -10\text{ V}$ for STZT2907 for STZT2907A $I_C = -10\text{ mA}$ $V_{CE} = -10\text{ V}$ for STZT2907 for STZT2907A $I_C = -150\text{ mA}$ $V_{CE} = -10\text{ V}$ $I_C = -500\text{ mA}$ $V_{CE} = -10\text{ V}$ for STZT2907 for STZT2907A	35 75 50 100 75 100 100 10 50		300	
f_T	Transition Frequency	$I_C = -10\text{ mA}$ $V_{CE} = -10\text{ V}$ $f = 100\text{ MHz}$	200			MHz
C_{CBO}	Collector-Base Capacitance	$I_E = 0$ $V_{CB} = -10\text{ V}$ $f = 1\text{ MHz}$			8	pF
C_{EBO}	Emitter-Base Capacitance	$I_C = 0$ $V_{EB} = -2\text{ V}$ $f = 1\text{ MHz}$			30	pF
t_d	Delay Time	$I_C = -150\text{ mA}$ $I_{B1} = -15\text{ mA}$ $V_{CC} = -30\text{ V}$			10	ns
t_r	Rise Time				40	ns
t_{on}	Turn-on Time				45	ns
t_s	Storage Time	$I_C = -150\text{ mA}$ $I_{B1} = -I_{B1} = -15\text{ mA}$ $V_{CC} = -30\text{ V}$			80	ns
t_f	Fall Time				30	ns
t_{off}	Turn-off Time				100	ns

* Pulsed: Pulse duration = 300 μs , duty cycle $\leq 1.5\%$

SOT223 MECHANICAL DATA

DIM.	mm			mils		
	MIN.	TYP.	MAX.	MIN.	TYP.	MAX.
a	2.27	2.3	2.33	89.4	90.6	91.7
b	4.57	4.6	4.63	179.9	181.1	182.3
c	0.2	0.4	0.6	7.9	15.7	23.6
d	0.63	0.65	0.67	24.8	25.6	26.4
e1	1.5	1.6	1.7	59.1	63	66.9
e4			0.32			12.6
f	2.9	3	3.1	114.2	118.1	122.1
g	0.67	0.7	0.73	26.4	27.6	28.7
l1	6.7	7	7.3	263.8	275.6	287.4
l2	3.5	3.5	3.7	137.8	137.8	145.7
L	6.3	6.5	6.7	248	255.9	263.8

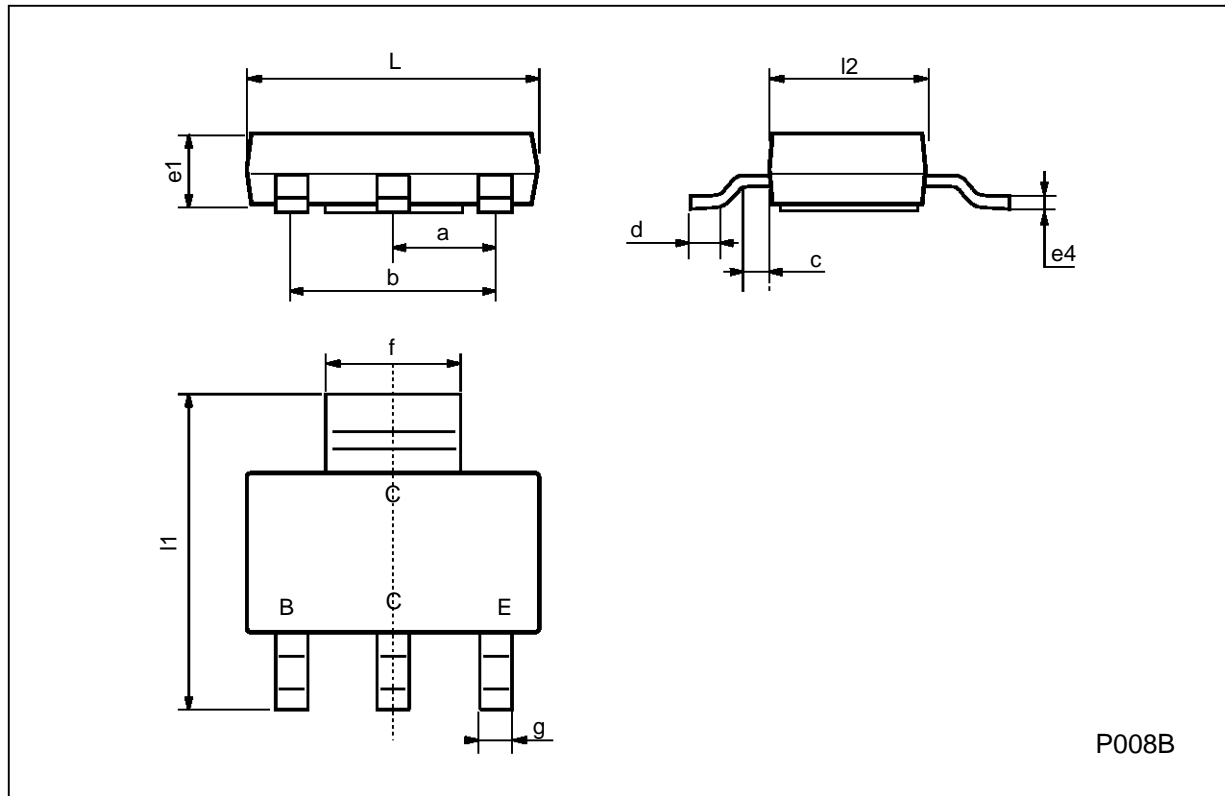

Information furnished is believed to be accurate and reliable. However, SGS-THOMSON Microelectronics assumes no responsibility for the consequences of use of such information nor for any infringement of patents or other rights of third parties which may result from its use. No license is granted by implication or otherwise under any patent or patent rights of SGS-THOMSON Microelectronics. Specifications mentioned in this publication are subject to change without notice. This publication supersedes and replaces all information previously supplied. SGS-THOMSON Microelectronics products are not authorized for use as critical components in life support devices or systems without express written approval of SGS-THOMSON Microelectronics.

© 1995 SGS-THOMSON Microelectronics - All Rights Reserved

SGS-THOMSON Microelectronics GROUP OF COMPANIES

Australia - Brazil - France - Germany - Hong Kong - Italy - Japan - Korea - Malaysia - Malta - Morocco - The Netherlands - Singapore - Spain - Sweden - Switzerland - Taiwan - Thailand - United Kingdom - U.S.A